



# **METHOD 302.0: DETERMINATION OF BROMATE IN DRINKING WATER USING TWO-DIMENSIONAL ION CHROMATOGRAPHY WITH SUPPRESSED CONDUCTIVITY DETECTION**



**METHOD 302.0      DETERMINATION OF BROMATE IN DRINKING WATER USING  
TWO-DIMENSIONAL ION CHROMATOGRAPHY WITH SUPPRESSED  
CONDUCTIVITY DETECTION**

**Version 1.0  
September 2009**

**Herbert P. Wagner (Lakeshore Engineering Services, Inc.)  
Barry V. Pepich (Shaw Environmental, Inc.)  
Chris Pohl, Kannan Srinivasan, Brian De Borba, Rong Lin (Dionex Corp.)  
David J. Munch (U.S. EPA, Office of Ground Water and Drinking Water)**

**TECHNICAL SUPPORT CENTER  
OFFICE OF GROUND WATER AND DRINKING WATER  
U. S. ENVIRONMENTAL PROTECTION AGENCY  
CINCINNATI, OHIO 45268**

## METHOD 302.0

### DETERMINATION OF BROMATE IN DRINKING WATERS USING TWO-DIMENSIONAL ION CHROMATOGRAPHY WITH SUPPRESSED CONDUCTIVITY DETECTION

#### 1. SCOPE AND APPLICATION

- 1.1 This is a large volume (1.0 mL), two-dimensional (2-D) ion chromatographic (IC) method using suppressed conductivity detection for the determination of bromate in raw and finished drinking waters. Because this method utilizes two dissimilar IC columns it does not require second column confirmation. Detection and quantitation in the second dimension are accomplished by suppressed conductivity detection. Precision and accuracy data have been generated for bromate using this 2-D IC method in reagent water, finished groundwater, finished surface water and a Laboratory Fortified Synthetic Sample Matrix (LFSSM). The single laboratory Lowest Concentration Minimum Reporting Level (LCMRL) has also been determined in reagent water.<sup>1</sup>

<u>Analyte</u>	<u>Chemical Abstract Services Registry Number (CASRN)</u>
Bromate	15541-45-4

- 1.2 The Minimum Reporting Level (MRL) is the lowest analyte concentration that meets Data Quality Objectives (DQOs) that are developed based on the intended use of this method. The single laboratory LCMRL is the lowest true concentration for which the future recovery is predicted to fall between 50 and 150 percent recovery with 99% confidence. The single laboratory LCMRL for bromate was 0.18 µg/L using a 1.0-mL injection volume (see Table 2). The procedure used to determine the LCMRL is described elsewhere.<sup>1</sup>
- 1.3 Laboratories using this method will not be required to determine the LCMRL, but will need to demonstrate that their laboratory MRL for this method meets the requirements described in Section 9.2.4.
- 1.4 Detection Limit (DL) is defined as the statistically calculated minimum concentration that can be measured with 99% confidence that the reported value is greater than zero.<sup>2</sup> The DL for bromate is dependent on sample matrix, fortification concentration, and instrument performance. Determining the DL for bromate in this method is optional (Sect. 9.2.6). The reagent water DL for bromate using a 1.0-mL injection volume was calculated to be 0.12 µg/L using 7 reagent water (RW) replicates fortified at 0.20 µg/L (see Table 2).
- 1.5 This method is intended for use by analysts skilled in the operation of IC instrumentation, and the interpretation of the associated data.
- 1.6 METHOD FLEXIBILITY – In recognition of technological advances in analytical systems and techniques, the laboratory is permitted to modify the separation technique, IC columns, concentrator column and mobile phase composition. However, any modifications must maintain the basic chromatographic elements of this new technique. This includes the initial

separation of analytes on a primary IC column that are heart-cut after suppression and directed to a concentrator column. After concentration, analytes must then be eluted onto a second, dissimilar IC column for separation and quantitation. For high sensitivity applications, the system should have a second-dimension column with a lower cross sectional area, which operates at a relatively lower flow rate in order to achieve sensitivity enhancement proportional to the ratio of the flow rate reduction. Method modifications should be considered only to improve method performance. Modifications that are introduced in the interest of reducing cost or sample processing time, but result in poorer method performance (see Sect. 9.4 for criteria), may not be used. In all cases where method modifications are proposed, the analyst must first redetermine the cut window and establish an acceptable calibration. Then the analyst must demonstrate acceptable method performance by conducting the procedures outlined in the initial demonstration of capability (IDC, Sect. 9.2), verifying that all ongoing QC acceptance criteria can be routinely met (Tables 4 and 5), and properly documenting the method changes (Sect. 9.4). **Changes may not be made to sample collection and preservation (Sect. 8) or to the quality control requirements (Sect. 9).**

## **2. SUMMARY OF METHOD**

- 2.1 Water samples are collected in the field using normal collection techniques and dechlorinated with ethylenediamine (EDA). A 1.0-mL sample aliquot is injected onto a 4-mm IC column. Separation of bromate is achieved in the first dimension (1-D) using 10 mM KOH at a flow rate of 1.0 mL per minute. Approximately 2 mL of the suppressed eluent containing the bromate is diverted from the first dimension column to a concentrator column used in place of the sample loop of the second dimension (2-D) injection valve. The concentrator column has low backpressure but sufficient capacity to trap the bromate ions quantitatively in the suppressed eluent. In this manner, bromate is separated from other matrix ions and concentrated on a trapping column. The heart-cut portion of the 1-D chromatogram is eluted off the concentrator column and onto a smaller diameter (2 mm diameter) guard and analytical column that have different selectivity from the first dimension columns to facilitate the 2-D separation using 10 mM KOH at a flow rate of 0.25 mL per minute. Bromate is quantitated using the external standard method.

There are several advantages to this version of the method. This version is compatible with a large sample injection volume (up to 1.0-mL). This is due to the high capacity of the 1-D analytical column and its higher selectivity for bromate relative to the other matrix ions. The suppressed eluent from the first dimension column, which is essentially water containing the anions of interest and a subset of the matrix interferences that co-elute in the heart-cut window, are efficiently retained and refocused on the concentrator column. Because the second dimension is operated at a lower flow rate relative to the first dimension and uses a smaller cross sectional area column, this version of the method offers enhanced sensitivity. The increase in sensitivity of the present setup is directly proportional to the flow rate ratio of the first dimension to the second dimension columns. This yields method sensitivity comparable to the EPA bromate methods that utilize the addition of postcolumn reagents (317.0 and 326.0) and UV/Vis detection. Finally, the 2-D IC method combines two columns with different selectivity thereby eliminating the need for second column confirmation.

### 3. DEFINITIONS

- 3.1 ANALYSIS BATCH – A sequence of field samples, which are analyzed within a 24-hour period and include no more than 20 field samples. An Analysis Batch must also include all required QC samples, which do not contribute to the maximum field sample total of 20. For this method, the required QC samples include:
- Laboratory Reagent Blank (LRB)
  - Continuing Calibration Check (CCC) Standards
  - Laboratory Fortified Sample Matrix (LFSM)
  - Laboratory Duplicate (LD) or a Laboratory Fortified Sample Matrix Duplicate (LFSMD)
  - Laboratory Fortified Synthetic Sample Matrix CCC Standard (LFSSM CCC)
- 3.2 ANALYTE FORTIFICATION SOLUTIONS (AFS) – The Analyte Fortification Solutions are prepared by dilution of the Analyte Secondary Dilution Solutions (SDS) and are used to fortify the LFSMs and the LFSMDs with bromate. It is recommended that multiple concentrations be prepared so that the fortification levels can be rotated or adjusted to the concentration of target analyte in the native samples.
- 3.3 CALIBRATION STANDARD (CAL) – A solution of the target analyte prepared from the Bromate Primary Dilution Solution or Bromate Stock Standard Solution. The CAL solutions are used to calibrate the instrument response with respect to analyte concentration.
- 3.4 CONTINUING CALIBRATION CHECK STANDARD (CCC) – A calibration check standard containing the method analyte which is analyzed periodically throughout an Analysis Batch, to verify the accuracy of the existing calibration for that analyte.
- 3.5 DETECTION LIMIT (DL) – The minimum concentration of an analyte that can be identified measured and reported with 99% confidence that the analyte concentration is greater than zero. This is a statistical determination (Sect. 9.2.6), and accurate quantitation is not expected at this level.<sup>2</sup>
- 3.6 LABORATORY DUPLICATE (LD) – Two sample aliquots (LD<sub>1</sub> and LD<sub>2</sub>), from a single field sample bottle, and analyzed separately with identical procedures. Analyses of LD<sub>1</sub> and LD<sub>2</sub> indicate precision associated specifically with laboratory procedures by removing variation contributed from sample collection and storage procedures.
- 3.7 LABORATORY FORTIFIED BLANK (LFB) – An aliquot of reagent water or other blank matrix to which a known quantity of the method analyte is added. The LFB is analyzed exactly like a sample. Its purpose is to determine whether the methodology is in control, and whether the laboratory is capable of making accurate and precise measurements.
- 3.8 LABORATORY FORTIFIED SAMPLE MATRIX (LFSM) – An aliquot of a field sample to which a known quantity of the method analyte is added. The LFSM is processed and analyzed exactly like a field sample, and its purpose is to determine whether the field sample matrix contributes bias to the analytical results. The background concentration of the analyte

in the field sample matrix must be determined in a separate aliquot and the measured value in the LFSM corrected for the native concentration.

- 3.9 LABORATORY FORTIFIED SAMPLE MATRIX DUPLICATE (LFSMD) – A second aliquot of the field sample used to prepare the LFSM, which is fortified and analyzed identically to the LFSM. The LFSMD is used instead of the Laboratory Duplicate to assess method precision and accuracy when the occurrence of the target analyte is infrequent.
- 3.10 LABORATORY FORTIFIED SYNTHETIC SAMPLE MATRIX (LFSSM) – An aliquot of the LSSM (Sect. 7.2.2) which is fortified with bromate. The LFSSM is used to set the start time for the cut window in the 1-D during the initial demonstration of capability (IDC) (Sect. 9.2). The LFSSM is also used to determine the precision and accuracy of the method during the IDC (Sects. 9.2.2 and 9.2.3). The LFSSM samples are treated like the CCCs.
- 3.11 LABORATORY FORTIFIED SYNTHETIC SAMPLE MATRIX CONTINUING CALIBRATION CHECK STANDARD (LFSSM CCC) – An aliquot of the LSSM (Sect. 7.2.2) which is fortified with bromate at a concentration equal to one of the CCCs. In this method, a LFSSM CCC at a concentration equal to the highest calibration level should be analyzed near the beginning of each Analysis Batch (Sect. 9.3.3) to confirm that the 1-D heart cutting procedure has acceptable recovery in high inorganic matrices.
- 3.12 LABORATORY REAGENT BLANK (LRB) – An aliquot of reagent water or other blank matrix that is treated exactly as a sample including exposure to storage containers. The LRB is used to determine if the method analyte or other interferences are present in the laboratory environment, the reagents, or the apparatus.
- 3.13 LABORATORY SYNTHETIC SAMPLE MATRIX (LSSM) – An aliquot of reagent water that is fortified with 100 mg/L of the sodium salts of chloride, bicarbonate and sulfate and 10 mg/L phosphate as phosphorus and nitrate as nitrogen using the sodium salts of phosphate and nitrate.
- 3.14 LOWEST CONCENTRATION MINIMUM REPORTING LEVEL (LCMRL) – The single-laboratory LCMRL is the lowest true concentration for which the future recovery is predicted to fall between 50 and 150 percent recovery with 99% confidence.<sup>1</sup>
- 3.15 MATERIAL SAFETY DATA SHEET (MSDS) – Written information provided by vendors concerning a chemical's toxicity, health hazards, physical properties, fire, and reactivity data including storage, spill, and handling precautions.
- 3.16 MINIMUM REPORTING LEVEL (MRL) – The minimum concentration that can be reported by a laboratory as a quantified value for the target analyte in a sample following analysis. This defined concentration must meet the criteria defined in Section 9.2.4 and must be no lower than the concentration of the lowest calibration standard for the target analyte.
- 3.17 PRIMARY DILUTION STANDARD SOLUTION (PDS) – A solution containing the method analyte prepared in the laboratory from stock standard solutions and diluted as needed to prepare calibration solutions and other analyte-containing solutions.

- 3.18 QUALITY CONTROL SAMPLE (QCS) – A solution containing the method analyte at a known concentration that is obtained from a source external to the laboratory and different from the source of calibration standards. The QCS is used to verify the accuracy of the calibration standards and the integrity of the calibration curve.
- 3.19 REAGENT WATER (RW) – Purified water which does not contain any measurable quantity of the target analyte or interfering compounds at or above 1/3 the MRL.
- 3.20 SECONDARY DILUTION STANDARD SOLUTION (SDS) – A solution containing the method analyte prepared in the laboratory from the PDS and diluted as needed to prepare calibration solutions and other analyte solutions.
- 3.21 STOCK STANDARD SOLUTION (SSS) – A concentrated solution containing the method analyte prepared in the laboratory using assayed reference materials or purchased from a reputable commercial source, so that the concentration and purity of analytes are traceable to certificates of analysis.

#### **4. INTERFERENCES**

- 4.1 Interferences can be divided into three different categories: (i) direct chromatographic co-elution, where an analyte response is observed at very nearly the same retention time (RT) as the target analyte; (ii) concentration dependant co-elution, which is observed when the response of higher than typical concentrations of the neighboring peak overlaps into the retention window of the target analyte; and (iii) ionic character displacement, where retention times may significantly shift due to the influence of high ionic strength matrices (high mineral content or total dissolved solids) overloading the exchange sites on the column and significantly shortening the target analyte's retention time.
- 4.1.1 A direct chromatographic co-elution may be solved by changing column selectivity in one or both dimensions of the 2-D IC method, adjusting eluent strength in one or both dimensions, modifying the eluent with organic solvents (if compatible with IC columns), changing the detection system, or selective removal of the interference with sample pretreatment. Sample dilution will have little to no effect on direct chromatographic co-elution. The analyst must verify that any change made to the chromatographic parameters does not induce any negative affects on method performance by repeating and passing all the QC criteria as described in Section 9.2.
- 4.1.2 Sample dilution may resolve some of the difficulties if the interference is the result of either concentration dependant co-elution or ionic character displacement, but it must be clarified that sample dilution will alter the MRL by a proportional factor equivalent to that of the dilution. Therefore, careful consideration of Data Quality Objectives (DQOs) should be given prior to performing such a dilution.
- 4.2 Method interferences may be caused by contaminants in solvents, reagents (including reagent water), sample bottles and caps, and other sample processing hardware that lead to discrete artifacts and/or elevated baselines in the chromatograms. All items such as these must be routinely demonstrated to be free from interferences (less than  $\frac{1}{3}$  the bromate MRL) by

analyses of an LRB as described in Section 9.2.1. **Subtracting blank values from sample results is not permitted.**

- 4.3 Matrix interferences may be caused by contaminants that are present in the sample. The extent of matrix interferences will vary considerably from source to source, depending upon the nature of the water. Water samples high in organic carbon or total dissolved solids may have elevated baselines or interfering peaks.
  - 4.3.1 Equipment and containers used for sample collection and storage have the potential to introduce interferences. The potential for interferences from these sources must be investigated during the IDC (Sect. 9.2) by preparing and analyzing a LRB. This procedure should be repeated each time that a new brand and/or lot of materials are used to ensure that contamination does not hinder analyte identification and quantitation.
- 4.4 When first-dimension heart-cut windows are properly set, this method demonstrates adequate performance in water matrices that contain up to 100 mg/L of each common anion (sulfate, bicarbonate, and chloride), and phosphate as phosphorus and nitrate as nitrogen at 10 mg/L. While this addresses the majority of source and finished drinking waters, there is a possibility that water matrices could exceed this level. The analyst should monitor all first dimension chromatograms (Sect. 11.3.4) to confirm that sample matrix does not overload the primary column capacity and require dilution.

## 5. **SAFETY**

- 5.1 The toxicity or carcinogenicity of each reagent used in this method has not been precisely defined. Each chemical should be treated as a potential health hazard, and exposure to these chemicals should be minimized. Each laboratory is responsible for maintaining an awareness of OSHA regulations regarding safe handling of chemicals used in this method. A reference file of MSDSs should be made available to all personnel involved in the chemical analysis. Additional references to laboratory safety are available.<sup>3-5</sup>

## 6. **EQUIPMENT AND SUPPLIES** (References to specific brands or catalog numbers are included for illustration only and do not imply endorsement of the product. This does not preclude the use of other vendors, supplies or configurations.)

- 6.1 **SAMPLE CONTAINERS** – 125-mL brown Nalgene bottles (Fisher Cat. No. 03-313-3C or equivalent).
- 6.2 **VOLUMETRIC FLASKS** – Class A, suggested sizes include 10, 50, 100, 250, 500 and 1000 mL for preparation of standards and eluents.
- 6.3 **GRADUATED CYLINDERS** – Suggested sizes include 25 and 1000 mL.
- 6.4 **AUTO PIPETTES** – Capable of delivering variable volumes from 1.0 to 2500  $\mu$ L.
- 6.5 **ANALYTICAL BALANCE** – Capable of weighing to the nearest 0.0001 g.



6.6 DUAL ION CHROMATOGRAPHY SYSTEM WITH SUPPRESSED CONDUCTIVITY DETECTION (IC) – This section describes the instrument configuration that was used to collect the data in Section 17. A Dionex Model ICS-3000 Dual system, consisting of a Dual Pump (DP) module, Eluent Generator (EG) module, Detector/Chromatography (DC) module, and Autosampler (AS), was used to collect the data presented in this method. Equivalent systems may be used. The IC system should also have a temperature controlled column compartment and be capable of operating above room temperature (30 °C) and include dual IC pumps and all required accessories, including guard, analytical, and concentrator columns, detector/chromatography module, dual eluent generators, continuously-regenerated anion trap columns, compressed gases, autosampler, suppressors, carbonate removal devices (CRD), dual conductivity detectors, and a computer-based data acquisition and control system. Additionally, the system must be capable of performing automated, two-dimensional IC, including performing inline column concentration and matrix elimination steps as described in Section 2.1. A schematic diagram of the instrumentation for this 2-D IC method is shown in Figure 1. Table 1 provides full details of the instrumental conditions.

6.6.1 DUAL PUMP MODULE – A DP Dual Gradient-Gradient Pumping Module with dual channel degas devices (Dionex DP, P/N 061712), was used to generate the data for this method. Equivalent modules may be used. The dual pump system used for method development was capable of supplying a flow rate of approximately 1.0 mL/min to the first dimension column and approximately 0.25 mL/min to the second dimension column.

6.6.2 ELUENT GENERATOR MODULE – A dual channel EG Module (Dionex EG, P/N 061714) with dual potassium hydroxide cartridges (EluGen<sup>®</sup> Cartridge, EGC, P/N 058900) was used to prepare the potassium hydroxide eluent for both the first and second dimensions of this method. An equivalent eluent generator may be used and/or manually prepared eluents may also be used provided that adequate resolution, peak shape, capacity, accuracy, and precision (Sect. 9.2) are obtained. Care must be exercised with manually prepared hydroxide eluents to prevent formation of carbonate in the eluent from exposure to the atmosphere, which can dramatically alter the chromatography and affect sensitivity.

6.6.2.1 CONTINUOUSLY REGENERATED ANION TRAP COLUMNS – IC eluent purification columns (Dionex CR-ATC, P/N 060477 or equivalent). Any in-line, resin-based manual or electrolytic trapping column that provides adequate eluent purification for ultra trace analysis and performance (Sect. 9.2) may be used. A CR-ATC device, or equivalent, was used for eluent purification for both the first and second dimension eluents.

**NOTE:** For the configuration in Figure 1, the pump and eluent generator modules in combination must be capable of delivering different isocratic eluent concentrations to the columns in the first and second dimension. The same requirement applies for manually prepared eluents with a dual pumping system; the pump system must be capable of delivering two different, independent isocratic concentrations of eluents to the first and second dimension columns. In addition, the system should also be capable of providing a step isocratic eluent concentration change or a controlled gradient change to both dimensions independently. This allows the first and second dimension columns to be cycled to a higher eluent concentration in order to clean

residual matrix components from the columns prior to introduction of the next sample. This is important to ensure maximum column life and to minimize potential carryover and/or interferences from one sample to the next.

- 6.6.3 DETECTOR/CHROMATOGRAPHY MODULE – A DC Module (Dionex DC, P/N 061793 or equivalent) equipped with dual injection valves and capable of maintaining the columns and the suppressors at 30 °C, and conductivity cell at 35 °C is recommended.

**NOTE:** For optimal performance of this system, the conductivity cell should be set at a higher temperature than the analytical columns. For example, if the columns are set at 30 °C, the cell should be set at 35 °C.

- 6.6.4 FIRST DIMENSION GUARD COLUMN – An IC column, 4 x 50-mm (Dionex IonPac® AG19, P/N 062887 or equivalent). Any guard column that provides adequate protection for the analytical column and does not have an adverse effect on the peak shape may be used.
- 6.6.5 FIRST DIMENSION ANALYTICAL COLUMN – An IC column, 4 x 250 mm (Dionex IonPac® AS19, P/N 062885 or equivalent). Any analytical column that provides adequate resolution, peak shape, capacity, accuracy, and precision (Sect. 9.2) may be used. The separation mechanism for the first dimension analytical column must differ from the second dimension column in selectivity.
- 6.6.6 FIRST DIMENSION ANION SUPPRESSOR DEVICE – An IC eluent suppression device, 4 mm (Dionex Anion Self-Regenerating Suppressor, ASRS Ultra II, P/N 061561 or equivalent). An equivalent in-line suppression device that effectively suppresses the conductance of the eluent and converts the analyte to the hydronium form prior to conductivity detection, as well as provides adequate efficiency, resolution, peak shape, capacity, accuracy, precision, and a comparable MRL and DL (Section 9.2) may be used. Adequate baseline stability should be attained as measured by a baseline noise of no more than 5 nS per minute over the background conductivity. The first dimension suppressor must be compatible with the first dimension guard and analytical column.

**NOTE:** The conductivity suppressor was set to perform electrolytic suppression at a current setting of 161 mA. It was important to operate the suppressor in the external water mode to reduce baseline noise and achieve optimal method performance.

- 6.6.7 FIRST DIMENSION CARBONATE REMOVAL DEVICE – An IC carbonate removal device, 4 mm (Dionex CRD, P/N 062983 or equivalent). Any in-line carbonate removal device that effectively removes the carbonate peak from the suppressed eluent stream prior to conductivity detection and provides adequate efficiency, resolution, peak shape, capacity, accuracy, and precision for bromate (Section 9.2) may be used. The first dimension CRD must be compatible with (e.g., 4 mm in this example) the first dimension guard and analytical column.
- 6.6.8 FIRST DIMENSION CONDUCTIVITY DETECTOR – A Conductivity detector and integrated cell (Dionex CD P/N 061716, or equivalent) capable of providing data as required in Section 9.2. A Standard Bore Temperature Stabilizer (0.010 inch ID, Dionex

P/N 062561), was also used to equilibrate the temperature of the eluent to that of the first dimension guard and analytical column. Equivalent stabilizers may be used.

**NOTE:** The conductivity detector cell temperature should be controlled at a temperature above that of the analytical column. For method development, the conductivity detector was set at 35 °C to minimize bubble formation and condensation between analytical column, suppressor and CRD and to stabilize the temperature of the detector cell itself.

6.6.9 CONCENTRATOR COLUMN – An IC trapping column, 5 x 23 mm (Dionex UTAC-ULP1, P/N 063475 or equivalent). Any concentrator column that provides effective retention/trapping and release of bromate while providing the resolution, peak shape, capacity, accuracy, and precision (Sect. 9.2) may be used. The concentrator column should not release sulfonated leachates that would affect the quantitation of bromate.

6.6.9.1 Alternate concentrator columns are allowed, but prior to their use, they must be evaluated to determine the first dimension cut window (Sect. 10.2.2). They must be determined to have sufficient capacity to quantitatively trap bromate in the LFSSM CCC (Sect. 10.3.3) and should have relatively low backpressure since the concentrator column is placed as a post-suppressor device.

6.6.10 SECOND DIMENSION GUARD COLUMN – An IC column, 2 x 50 mm (Dionex IonPac® AG24, P/N 064151 or equivalent). Any guard column that provides adequate protection for the analytical column and does not have an adverse effect on the peak shape may be used.

6.6.11 SECOND DIMENSION ANALYTICAL COLUMN – An IC column, 2 x 250 mm (Dionex IonPac® AS24, P/N 064153 or equivalent). Any analytical column that provides adequate resolution, peak shape, capacity, accuracy, and precision (Sect. 9.2) may be used. The separation mechanism for the second dimension analytical column must differ from the first dimension column.

6.6.12 SECOND DIMENSION ANION SUPPRESSOR DEVICE – An IC eluent suppression device, 2 mm (Dionex Anion Self-Regenerating Suppressor, ASRS Ultra II, P/N 061562 or equivalent). An equivalent in-line suppression device that effectively suppresses the conductance of the eluent prior to conductivity detection, and that provides adequate efficiency, resolution, peak shape, capacity, accuracy, precision, and a comparable MRL and DL (Section 9.2) may be used. Adequate baseline stability should be attained as measured by a baseline noise of no more than 5 nS per minute over the background conductivity. The second-dimension suppressor must be compatible with (e.g., 2 mm in this example) the second-dimension guard and analytical column.

**NOTE:** The conductivity suppressor was set to perform electrolytic suppression at a current setting of 41 mA. It was important to operate the suppressor in the external water mode to reduce baseline noise and achieve optimal method performance.

6.6.13 SECOND DIMENSION CARBONATE REMOVAL DEVICE – An IC carbonate removal device (Dionex CRD, P/N 062986 or equivalent). Any in-line carbonate removal device that effectively removes the carbonate peak from the suppressed eluent

stream prior to conductivity detection of the method analyte and provides adequate efficiency, resolution, peak shape, capacity, accuracy, and precision (Section 9.2) may be used. The second dimension CRD must be compatible with the second dimension guard and analytical column.

6.6.14 SECOND DIMENSION CONDUCTIVITY DETECTOR – A Conductivity detector and integrated cell (Dionex CD P/N 061716, or equivalent) capable of providing data as required in Section 9.2. A Microbore Temperature Stabilizer (0.005 inch ID, Dionex P/N 062562, or equivalent), was also used to equilibrate the temperature of the eluent to that of the second dimension guard and analytical column.

**NOTE:** The conductivity detector cell temperature should be controlled at a temperature above the analytical column. For method development, the conductivity was set at 35 °C to minimize bubble formation and condensation between analytical column, suppressor and CRD and to stabilize the temperature of the detector cell itself.

6.6.15 AUTOSAMPLER MODULE – An AS Autosampler Module with simultaneous injection, a sample prep option, and a large volume sample needle assembly (Dionex AS P/N 063105) was used to generate data for this method. Any autosampler capable of automatically injecting up to 1.0 mL of sample may be used.

6.6.16 DATA SYSTEM – An interfaced data system such as Dionex, Chromeleon Version 6.7 (or equivalent) is required to acquire, store, and output conductivity data. The computer software should have the capability of processing stored conductivity data by recognizing and integrating a peak within a given retention time window. The software should be capable of constructing linear regressions or quadratic calibration curves, and calculating analyte concentrations using the calibrations.

## 7. **REAGENTS AND STANDARDS**

7.1 REAGENTS – Reagent grade or better chemicals should be used in all tests. Unless otherwise indicated, it is intended that all reagents will conform to the specifications of the Committee on Analytical Reagents of the American Chemical Society (ACS), where such specifications are available. Other grades may be used, provided it is first determined that the reagent is of sufficiently high purity to permit its use without lessening the quality of the determination.

7.1.1 REAGENT WATER (RW) – Purified water that does not contain any measurable quantity of the target analyte or interfering compounds at or above 1/3 the bromate MRL. The purity of the water required for this method cannot be over emphasized. The reagent water used during method development was purified from tap water using a Millipore ELIX-3 followed by a Millipore Gradient A10 system. The water should contain no particles larger than 0.20 microns.

7.1.2 ELUENT SOLUTIONS – Two hydroxide eluent concentrations were used to collect the data in Section 17. A potassium hydroxide eluent concentration of 10 mM was used for the first dimension matrix elimination separation on the AS19 column, and 10 mM for the second dimension separation on the AS24 column. In addition, a hydroxide eluent

concentration of 65 mM was delivered to the first dimension column after the bromate heart-cut step was completed to ensure the column was properly cleaned prior to the next analysis. As well, the second dimension AS24 column was cleaned with 65 mM hydroxide after the elution of bromate and equilibrated with 10 mM hydroxide prior to injection of the next sample. These eluents were automatically prepared using electrolytic eluent generation with the ICS-3000 EG Eluent Generator and EluGen potassium hydroxide cartridges (Sect 6.6.2). They may also be manually prepared (Sect. 6.6.2) if adequate precautions are used to prevent carbonate formation from exposure to laboratory air.

- 7.1.2 BROMATE STANDARD – ( $\text{BrO}_3^-$ , CASRN 15541-45-4) – Ultra Scientific Cat. No. ULICC-010 or equivalent.
  - 7.1.3 SODIUM BICARBONATE – ( $\text{NaHCO}_3$ , CASRN 497-19-8) – Fluka Cat. No. 71627 or equivalent.
  - 7.1.4 SODIUM BROMATE – ( $\text{NaBrO}_3$ , CASRN 7789-38-0) – EM Science Cat. No. SX0385-1 or equivalent.
  - 7.1.5 SODIUM CHLORIDE – ( $\text{NaCl}$ , CASRN 7647-14-5) – Fisher Scientific Cat. No. S-271 or equivalent.
  - 7.1.6 SODIUM NITRATE – ( $\text{NaNO}_3$ , CASRN 7631-99-4) – Fisher Scientific Cat. No. S343-500) or equivalent.
  - 7.1.7 SODIUM PHOSPHATE, DIBASIC, ANHYDROUS – ( $\text{Na}_2\text{HPO}_4$ , CASRN 10140-65-5) JT. Baker Cat. No. 4062-1 or equivalent.
  - 7.1.8 SODIUM SULFATE – ( $\text{Na}_2\text{SO}_4$ , CASRN 7757-82-6) – Fluka Cat. No. 71959 or equivalent.
  - 7.1.9 ETHYLENEDIAMINE (EDA) PRESERVATION SOLUTION (10 mg/mL) – Add 2.8 mL of ethylenediamine (99%) (CASRN 19559-59-2) to a 250-mL volumetric flask and dilute to volume with reagent water.
- 7.2 STANDARD SOLUTIONS – When a compound purity is assayed to be 96 percent or greater, the weight can be used without correction to calculate the concentration of the stock standard. Solution concentrations listed in this section were used to develop this method and are included only as an example. **Although estimated stability times for standard solutions are suggested in the following subsections, laboratories should use standard QC practices to determine when their standards need to be replaced.**
- 7.2.1 BROMATE STANDARD SOLUTIONS – Obtain the analyte as a solid standard or as a commercially prepared standard from a reputable standard manufacturer. Prepare the bromate stock and dilution solutions as described below.
    - 7.2.1.1 BROMATE STOCK STANDARD SOLUTION (SSS) (1000 mg/L  $\text{BrO}_3^-$ ) – Preparation of this solution is accomplished using a solid  $\text{NaBrO}_3$  standard. Weigh

out 118.0 mg of  $\text{NaBrO}_3$  into a 100-mL volumetric flask and dilute to volume with reagent water. When stored in opaque, plastic storage bottles, the resulting stock solution may be stable for up to one year.

7.2.1.2 BROMATE PRIMARY DILUTION SOLUTION (PDS) ( $10.0 \text{ mg/L BrO}_3^-$ ) – Prepare the Bromate PDS by adding 1.0 mL of the Bromate SSS to a 100-mL volumetric flask and dilute to volume with reagent water. This solution is used to prepare the Bromate Secondary Dilution Standard Solution, the Bromate Fortification Solutions and the Calibration Solutions below. When stored in opaque, plastic storage bottles, the resulting solution is stable for at least one month.

7.2.1.3 BROMATE SECONDARY DILUTION SOLUTION (SDS) ( $1.0 \text{ mg/L BrO}_3^-$ ) – Prepare the 1.0 mg/L Bromate SDS by adding 10.0 mL of the Bromate PDS to a 100-mL volumetric flask and diluting to volume with reagent water. This solution is used to prepare the Bromate Fortification Solutions, CAL and CCC Standards listed below. When stored in opaque, plastic storage bottles, the resulting solution is stable for at least one month.

7.2.1.4 BROMATE FORTIFICATION SOLUTIONS (BFS) ( $50, 200 \text{ and } 500 \mu\text{g/L BrO}_3^-$ ) – The Bromate Fortification Solutions are prepared by dilution of the Bromate SDS and are used to fortify the Laboratory Fortified Blank (LFB), the Laboratory Fortified Sample Matrix (LFSM), the Laboratory Fortified Sample Matrix Duplicate (LFSMD) and the Laboratory Fortified Synthetic Sample Matrix (LFSSM) with bromate. It is recommended that multiple concentrations be prepared so that the fortification levels can be rotated or adjusted to the concentration of the target analyte in the native samples. When stored in opaque, plastic storage bottles, the resulting solutions are stable for at least one month.

7.2.2 LABORATORY SYNTHETIC SAMPLE MATRIX (LSSM) – Prepare a LSSM that contains the common anions chloride, sulfate and bicarbonate at 100 mg/L, and phosphate as phosphorus and nitrate as nitrogen at 10 mg/L as follows.

7.2.2.1 Weigh out 276 mg of  $\text{NaHCO}_3$ , 296 mg of  $\text{Na}_2\text{SO}_4$ , 330 mg of  $\text{NaCl}$ , 91.7 mg of  $\text{Na}_2\text{HPO}_4$  and 121 mg of  $\text{NaNO}_3$ . Add these to a 2000-mL volumetric flask using a funnel and dilute to volume using reagent water.

7.3 CALIBRATION STANDARDS (CAL) – Prepare a calibration curve from dilutions of the Bromate PDS and the Bromate SDS using a minimum of five Calibration Standards, which span the concentration range of interest. The lowest CAL standard must be at or below the MRL. An example of the dilutions used to prepare the CAL standards used to collect the data in Section 17 are shown in the Table below.

CAL and CCC Levels	Vol. of BrO <sub>3</sub> <sup>-</sup> PDS (μL)	Vol. of BrO <sub>3</sub> <sup>-</sup> SDS (μL)	Final Vol. of Std. (mL)	Final Conc. of BrO <sub>3</sub> <sup>-</sup> (μg/L)
CAL 1		15	100	0.15
CAL 2		25	100	0.25
CAL 3		50	100	0.50
CAL 4		100	100	1.00
CAL 5	30		100	3.00
CAL 6	50		100	5.00
CAL 7	100		100	10.0
CAL 8	150		100	15.0

- 7.4 CONTINUING CALIBRATION CHECK STANDARDS (CCC) – Prepare the CCC standards from dilutions of the Bromate PDS and the Bromate SDS at three concentrations representing the low, mid and high points of the calibration curve. The low-level CCC should be at or below the MRL.
- 7.5 LABORATORY FORTIFIED SYNTHETIC SAMPLE MATRIX CCC STANDARD – In order to ensure that the first dimension cut window is functioning properly during each analysis batch, a CCC is also prepared in the laboratory synthetic sample matrix. This solution is termed the Laboratory Fortified Synthetic Sample Matrix (LFSSM) CCC and is analyzed following the last high-level CCC during each Analysis Batch.

## **8. SAMPLE COLLECTION, PRESERVATION, AND STORAGE**

### 8.1 SAMPLE COLLECTION

- 8.1.1 Grab samples must be collected in plastic or glass containers accordance with conventional sampling practices.<sup>6</sup>
- 8.1.2 When sampling from a cold water tap, open the tap and allow the system to flush until the water temperature has stabilized (usually approximately 3 to 5 minutes). Collect a representative sample from the flowing system using a beaker of appropriate size. Use this bulk sample to generate individual samples as needed. A volume of approximately 20-mL is required for each individual sample.
- 8.1.3 When sampling from an open body of water, fill a beaker with water sampled from a representative area. Use this bulk sample to generate individual samples as needed. A volume of approximately 20-mL of sample is required for each individual sample.
- 8.1.4 Samples must be dechlorinated at the time of collection by adding EDA so that the final concentration in the sample container is 50 mg/L. For a 20 mL sample, this would require 100 uL of the EDA Preservation Solution (Sect. 7.1.9).

- 8.2 **SAMPLE SHIPMENT AND STORAGE** – Field samples must be chilled during shipment and must not exceed 10 °C during the first 48 hours after collection. Field samples should be confirmed to be at or below 10 °C when they are received at the laboratory. Field samples stored in the lab must be held at or below 6 °C until analysis.
- 8.3 **SAMPLE HOLDING TIMES** – Field samples that are collected and stored as described in Sections 8.1 and 8.2 may be held for up to 28 days.

## 9. **QUALITY CONTROL**

- 9.1. Quality Control requirements include the Initial Demonstration of Capability (IDC) and ongoing QC requirements that must be met when preparing and analyzing field samples. This section describes each QC parameter, its required frequency, and the performance criteria that must be met in order to meet EPA data quality objectives. The QC criteria discussed in the following sections are summarized in Section 17, Tables 4 and 5. These QC requirements are considered the minimum acceptable QC criteria. Laboratories are encouraged to institute additional QC practices to meet their specific needs.
- 9.2 **INITIAL DEMONSTRATION OF CAPABILITY (IDC)** – The IDC must be successfully performed prior to analyzing any field samples. Prior to conducting the IDC, the analyst must first meet the calibration requirements outlined in Section 10. Requirements for the IDC are described in the following sections and are summarized in Table 4.
- 9.2.1 **DEMONSTRATION OF LOW SYSTEM BACKGROUND** – Analyze a Laboratory Reagent Blank (LRB) processed through all sample collection steps outlined in Section 8.1. Confirm that the LRB is reasonably free of contamination ( $\leq 1/3$  the MRL) and that the criteria in Section 9.3.1 are met.

**NOTE:** It is a good laboratory practice to include a blank in the calibration of any instrument. The method should also be checked for carry-over by analyzing a RW blank immediately following the highest CAL standard. If this RW sample does not meet the criteria outlined in Section 9.3.1 then carry-over is present and should be identified and eliminated.

- 9.2.2 **DEMONSTRATION OF PRECISION** – Prepare and analyze 7 replicate LFBs and LFSSMs fortified near the midrange of the initial calibration curve. The percent relative standard deviation (%RSD) of the results of the replicate analyses must be  $\leq 20$  percent.

$$\% \text{ RSD} = \frac{\text{Standard Deviation of Measured Concentrations}}{\text{Average Concentration}} \times 100$$

- 9.2.3 **DEMONSTRATION OF ACCURACY** – Using the same set of replicate data generated for Section 9.2.2, calculate average recovery. The average recovery of the replicate values must be within  $\pm 20$  percent of the true value.

$$\% \text{ Recovery} = \frac{\text{Average Measured Concentration}}{\text{Fortified Concentration}} \times 100$$



9.2.4 MINIMUM REPORTING LEVEL (MRL) CONFIRMATION – Establish a target concentration for the MRL based on the intended use of the method. The lowest calibration standard used to establish the initial calibration (as well as the low-level CCC) must be at or below the concentration of the MRL. Establishing the MRL concentration too low may cause repeated failure of ongoing QC requirements. Confirm or validate the MRL following the procedure outlined below.

9.2.4.1 Fortify and analyze seven replicate LFB at or below the proposed MRL concentration. Calculate the mean (*Mean*) and standard deviation (*S*) for these replicates. Determine the Half Range for the Prediction Interval of Results ( $HR_{PIR}$ ) using the equation below.

$$HR_{PIR} = 3.963S$$

where *S* is the standard deviation, and 3.963 is a constant value for seven replicates.<sup>1</sup>

9.2.4.2 Confirm that the upper and lower limits for the Prediction Interval of Results ( $PIR = Mean \pm HR_{PIR}$ ) meet the upper and lower recovery limits as shown below.

The Upper PIR Limit must be  $\leq 150$  percent recovery.

$$\frac{Mean + HR_{PIR}}{FortifiedConcentration} \times 100 \leq 150\%$$

The Lower PIR Limit must be  $\geq 50$  percent recovery.

$$\frac{Mean - HR_{PIR}}{FortifiedConcentration} \times 100 \geq 50\%$$

9.2.4.3 The MRL is validated if both the Upper and Lower PIR Limits meet the criteria described above (Sect. 9.2.4.2). If these criteria are not met, the MRL has been set too low and must be determined again at a higher concentration.

9.2.5 QUALITY CONTROL SAMPLE (QCS) – Analyze a mid-level Quality Control Sample (Sect. 9.3.7) to confirm the accuracy of the calibration curve fit.

9.2.6 DETECTION LIMIT DETERMINATION (DL) (optional) – *While DL determination is not a specific requirement of this method, it may be required by various regulatory bodies associated with compliance monitoring. It is the responsibility of the laboratory to determine if DL determination is required based upon the intended use of the data.*

Analyses for this procedure should be done over at least 3 days. Prepare and analyze at least 7 replicate fortified LFBs. Use the solutions described in Section 7.2.1.4 to fortify at a concentration estimated to be near the DL. This fortification concentration may be

estimated by selecting a concentration at 2-5 times the noise level. Analyze the seven replicates through all steps of Section 11.

**NOTE:** If an MRL confirmation data set meets these requirements, a DL may be calculated from the MRL confirmation data, and no additional analyses are necessary.

Calculate the DL using the following equation:

$$DL = St_{(n-1, 1-\alpha=0.99)}$$

where:

$t_{(n-1, 1-\alpha=0.99)}$  = Student's t value for the 99% confidence level with n-1 degrees of freedom

n = number of replicates

S = standard deviation of replicate analyses.

**NOTE:** Do not subtract blank values when performing DL calculations.

9.3 ONGOING QC REQUIREMENTS – This section describes the ongoing QC criteria that must be followed when processing and analyzing field samples. Table 5 summarizes these requirements.

9.3.1 LABORATORY REAGENT BLANK (LRB) – A LRB is analyzed during the IDC and is required with each Analysis Batch (Sect. 3.1) to confirm that potential background contaminants are not interfering with the identification or quantitation of bromate. If within the retention time window of any analyte, the LRB produces a peak that would prevent the determination of bromate, determine the source of contamination and eliminate the interference before processing samples. Background from target analytes or contaminants that interfere with the measurement of target analytes must be  $\leq 1/3$  the MRL. If the target analytes are detected in the LRB at concentrations equal to or greater than this level, then all data for the problem analyte(s) must be considered invalid for all samples which yielded a positive result.

**NOTE:** Although quantitative data below the MRL may not be accurate enough for data reporting, such data are useful in determining the magnitude of a background interference. Therefore, blank contamination levels may be estimated by extrapolation, when the concentration is below the MRL.

9.3.2 CONTINUING CALIBRATION CHECK STANDARDS (CCC) – CCC standards are analyzed at the beginning of each Analysis Batch, after every ten field samples, and at the end of the Analysis Batch. See Section 10.3 and Table 5 for concentration requirements and acceptance criteria.

9.3.3 LABORATORY FORTIFIED SYNTHETIC SAMPLE MATRIX CCC STANDARD (LFSSM CCC) – A CCC standard prepared in the LSSM at the same concentration as the high-level CCC Standard should be analyzed at the end of each Analysis Batch. The LFSSM CCC is used to ensure the integrity of the sample pre-concentration/matrix elimination step and the chromatographic separation of bromate from other interfering

anionic species in very high ionic matrices. See Section 10.3.3. and Table 5 for concentration requirements and acceptance criteria.

- 9.3.4 LABORATORY FORTIFIED BLANK (LFB) – A LFB is required with each Analysis Batch. In successive analysis batches, the LFB fortification level must be rotated between low, medium, and high. The low concentration LFB must be at or below the MRL. Results of LFBs fortified at  $\leq$  MRL must be within 50-150% of the true value. Results of LFB analyses from all other concentrations must be 80-120% of the true value. If the LFB results do not meet these criteria, then all data for bromate must be considered invalid for all samples in the Analysis Batch.
- 9.3.5 LABORATORY FORTIFIED SAMPLE MATRIX (LFSM) – Analysis of a LFSM (Sect. 3.8) is required in each Analysis Batch. The LFSM is processed and analyzed exactly like a traditional sample, and its purpose is to determine whether the sample matrix contributes bias to the analytical results. The native concentration of the analyte in the sample matrix must be determined in a separate aliquot and the measured value in the LFSM corrected for the native concentration. If a variety of different sample matrices are analyzed regularly, for example drinking water from groundwater and surface water sources, performance data should be collected for each source.

- 9.3.5.1 Within each Analysis Batch, a minimum of one field sample must be fortified as an LFSM for every 20 field samples analyzed. The LFSM is prepared by spiking a field sample with an appropriate amount of the Bromate Fortification Solutions (Sect. 7.2.1.4). The fortification should be delivered in the smallest volume possible to minimize dilution of the sample. Select a fortification concentration that is equal to or greater than the native concentration, if known. Use historical data and rotate through the designated concentrations when selecting a fortifying concentration.

Calculate the percent recovery (%REC) using the equation

$$\% \text{REC} = \frac{(A - B)}{C} \times 100$$

A = measured concentration in the fortified sample  
B = measured concentration in the unfortified sample  
C = fortification concentration

- 9.3.5.2 Recoveries for samples fortified at concentrations near or at the MRL (within a factor of two times the MRL concentration) should be 50-150%. Recoveries for samples fortified at all other concentrations should be 80-120%. If the accuracy for any analyte falls outside the designated range, and the laboratory performance for that analyte is shown to be in control in the CCCs and the LFSSM CCC, the recovery is judged to be matrix biased. The result for that analyte in the unfortified sample is labeled “suspect/matrix” to inform the data user that the results are suspect due to matrix effects.

- 9.3.5.2.1 Field samples that have a native bromate concentrations above the DL but below the MRL and are fortified at concentrations at or near the lowest

calibration standard should be corrected for the native levels in order to obtain meaningful percent recovery values. This example and the LRB (Sect. 9.3.1) are the only permitted use of analyte results below the MRL.

9.3.6 LABORATORY DUPLICATE OR LABORATORY FORTIFIED SAMPLE MATRIX DUPLICATE (LD or LFSMD) – Within each Analysis Batch, a minimum of one Laboratory Duplicate (LD) or Laboratory Fortified Sample Matrix Duplicate (LFSMD) must be analyzed. Laboratory Duplicates check the precision associated with laboratory procedures. If target analytes are not routinely observed in field samples, a LFSMD should be analyzed rather than a LD.

9.3.6.1 Calculate the relative percent difference (RPD) for duplicate measurements (LD<sub>1</sub> and LD<sub>2</sub>) using the equation

$$RPD = \frac{|LD_1 - LD_2|}{(LD_1 + LD_2)/2} \times 100$$

9.3.6.2 RPDs for Laboratory Duplicates should be  $\leq 20\%$ . Greater variability may be observed when Laboratory Duplicates have analyte concentrations that are within a factor of 2 of the MRL. At these concentrations Laboratory Duplicates should have RPDs that are  $\leq 50$  percent. If the RPD of any analyte falls outside the designated range, and the laboratory performance for that analyte is shown to be in control in the CCCs and LFSSM CCC, the recovery is judged to be matrix influenced. The result for that analyte in the unfortified field sample is labeled “suspect/matrix” to inform the data user that the results are suspect due to matrix effects.

9.3.6.3 If a LFSMD is analyzed instead of a Laboratory Duplicate, calculate the relative percent difference (RPD) for duplicate LFSMs (LFSM and LFSMD) using the equation.

$$RPD = \frac{|LFSM - LFSMD|}{(LFSM + LFSMD)/2} \times 100$$

9.3.6.4 RPDs for duplicate LFSMs must be  $\leq 20\%$ . Greater variability may be observed when LFSMs are fortified at analyte concentrations that are within a factor of 2 of the MRL. LFSMs fortified at these concentrations must have RPDs that are  $\leq 50\%$ . If the RPD of any analyte falls outside the designated range, and the laboratory performance for that analyte is shown to be in control in the CCCs and LFSSM CCC, the precision is judged to be matrix influenced. The result for that analyte in the unfortified field sample is labeled “suspect/matrix” to inform the data user that the results are suspect due to matrix effects.

9.3.7 QUALITY CONTROL SAMPLES (QCS) –A QCS must be evaluated as part of the IDC (Sect. 9.2.5) and each time new PDS solutions are prepared. If standards are prepared infrequently, analyze a QCS at least quarterly. The QCS should be fortified near the midpoint of the calibration range and analyzed as a CCC. The acceptance criteria for the

QCS is the same as for the mid- and high-level CCCs (Section 10.3). If measured analyte concentrations are not of acceptable accuracy, check the entire analytical procedure to locate and correct the problem.

- 9.4 METHOD MODIFICATION QC REQUIREMENTS – The analyst is permitted to modify the separation technique, IC columns, concentrator column and mobile phase composition. However, any modifications must maintain the basic chromatographic elements of this new technique (Sect 1.6).
- 9.4.1 Each time method modifications are made, the analyst must first redetermine the cut window following Section 10.2.2 using bromate solutions fortified into RW and the LSSM (Sect. 7.2.2) and then reestablish an acceptable initial calibration (Sect. 10.2.3). Alternate configurations may require modification of this technique. If alternate procedures are used, the analyst must still employ the LSSM and RW matrices to set the start and stop times of the cut windows.
- 9.4.2 Repeat the procedures of the IDC (Sect. 9.2) and verify that all Ongoing QC criteria can be met for the proposed method modification (Sect. 9.3).
- 9.4.3 The analyst is also required to evaluate method performance for the proposed method modifications in real matrices that span the range of waters that the laboratory analyzes. This additional step is required because modifications that perform acceptably during the IDC, which is conducted in reagent water and the LSSM, can fail ongoing method QC requirements in real matrices due to common method interferences. If, for example, the laboratory analyzes finished waters from both surface and groundwater municipalities, this requirement can be accomplished by assessing precision and accuracy (Sects. 9.2.2 and 9.2.3) in a surface water with moderate to high total organic carbon ( e.g., 2 mg/L or greater) and a hard groundwater (e.g., 250 mg/L or greater).
- 9.4.4 The results of Sections 9.4.1 – 9.4.3 must be appropriately documented by the analyst and should be independently assessed by the laboratory’s QA officer prior to its application to field samples.
- 9.4.4.1 When implementing method modifications, it is the responsibility of the laboratory to closely review the results of Ongoing QC, and in particular, the results associated with the LFSM (Sect. 9.3.5), the LFSMD (Sect. 9.3.6) and the LFSSM CCCs (Sect. 9.3.3). If repeated failures are noted, the modification must be abandoned.

## **10. CALIBRATION AND STANDARDIZATION**

- 10.1 Demonstration and documentation of acceptable initial calibration for bromate is required prior to conducting the IDC and before any field samples are analyzed. If the initial calibration is successful, continuing calibration check standards are required at the beginning and end of each Analysis Batch, as well as after every tenth field sample.
- 10.2 INITIAL CALIBRATION – The initial calibration must be established prior to conducting the IDC (Section 9.2) and may be reestablished prior to analyzing field samples. However, it is permissible to verify the calibration with daily CCCs. Calibration should be performed

using peak areas and the external standard technique. Calibration using peak heights is not permitted.

10.2.1 INSTRUMENT CONDITIONS – Establish proper operating conditions. Operating conditions used during method development are described in Section 17 Table 1. Conditions different from those described may be used if the IDC QC criteria in Section 9.2 are met. The procedure used to establish the first dimension cut window is provided in Section 10.2.2 below.

**NOTE:** For 2D-IC techniques, increased method sensitivity is achieved by injecting larger volumes. Increased injection volume must be carefully evaluated for each set of instrument conditions. For the conditions and equipment reported in this method, the maximum recommended injection volume is 1.0 mL. This is because bromate elutes just prior to chloride on the first dimension column. Injection volumes above 1.0 mL may cause potential chloride interference.

10.2.2 FIRST DIMENSION CUT WINDOW DETERMINATION – Since a large volume (1.0 mL) is injected onto the first dimension column, the affect of high ionic strength matrices on the bromate retention time requires careful consideration. Determination of the cut window is the first step in separating bromate from other interfering anionic matrix species. Setting of the cut window in the first dimension must include evaluation of the retention time for bromate in both RW and the LSSM.

**NOTE:** The procedure described below is applicable to the equipment configuration listed in Section 6. However, since acceptable modifications to this method require heart-cutting of bromate, the trapping of bromate on a concentrator column, and the subsequent separation and quantitation on a dissimilar analytical column, all modified versions of this procedure require the proper determination of the cut window. Similar techniques must therefore be developed and used by analysts using modified methods.

10.2.2.1 DETERMINING THE START TIME OF THE CUT WINDOW – Inject an aliquot (1.0 mL) of a 15 ug/L bromate fortification in the LSSM (without injection valve #2 on system #2 being activated) to determine the start time for the cut window. The start time for the cut window in the first dimension should be set at 0.50 minutes prior to the start of the bromate elution in the LSSM.

**NOTE:** The bromate in the LSSM may not appear as a distinct peak, but rather as a broad, smeared peak on the first dimension column. However, a distinct rise in baseline is evident when bromate starts to elute from the column (see Figure 3).

10.2.2.2 DETERMINING THE STOP TIME OF THE CUT WINDOW – The stop time for the cut window is established using reagent water. Inject an aliquot (1.0 mL) of a 15 ug/L bromate standard in RW and determine when bromate is completely eluted off the first dimension column. The stop time for the cut window in the first dimension should be set at 0.20 minutes after the bromate peak in RW returns to baseline.

**NOTE:** Since the stop time for the cut window is also the time at which injection valve #2 on system #2 is switched to the inject position, the elution of bromate must be completed at least 15 seconds before injection valve #2 is switched into the inject position when this instrument configuration is used (see Figure 3).

10.2.3 CALIBRATION – Prepare a set of at least five CAL standards as described in Section 7.3. The lowest concentration CAL standard must be at or below the MRL. The MRL must be confirmed using the procedure outlined in Section 9.2.4, after establishing the initial calibration. Calibrate the conductivity detector using the external standard technique. Calibration curves may be generated using the IC data system through the use of first (linear) or second (quadratic) order calibration curves. A quadratic fit is recommended for this method. Concentration-based weighting may also be used; however, if this approach is chosen the analyst must confirm this fit does not introduce bias in the higher concentration region of the curve.

10.2.3.1 CALIBRATION ACCEPTANCE CRITERIA – The validation of the calibration is determined by calculating the concentration of the analyte from each of the analyses used to generate the calibration curve. At least one CAL standard must be at or below the MRL. This calibration point should calculate to be 50 to 150 percent of its true value. All other higher concentration calibration points should calculate to be 80 to 120 percent of their true values. If these criteria cannot be met, the analyst will have difficulty meeting ongoing QC criteria. In this case, corrective action should be taken to reanalyze the calibration standards, restrict the range of calibration, or select an alternate method of calibration.

10.3 CONTINUING CALIBRATION CHECK (CCC) STANDARDS – The CCCs verify the calibration at the beginning and end of each group of analyses, as well as after every 10<sup>th</sup> field sample. The LRBs, LFBs, LFSSMs, LFSMs, LFSMDs, and CCCs are not counted as field samples. The beginning CCC for each Analysis Batch must be at or below the MRL in order to verify instrument sensitivity and the accuracy of the calibration curve prior to the analysis of any field samples. Subsequent CCCs should alternate between a medium and high concentration.

10.3.1 Inject an aliquot of the CCC standards and analyze with the same conditions used during the initial calibration.

10.3.2 Calculate the concentration of the analyte in the CCC standards. The calculated amount for the analyte for mid and high level CCCs must be within  $\pm 20$  percent of the true value. The calculated analyte amount for the lowest CCC level must be within  $\pm 50$  percent of the true value. If these conditions do not exist, then all data for the analyte must be considered invalid, and remedial action (Sect. 10.3.4) must be taken which may require recalibration. Any results from field samples that have been analyzed since the last acceptable calibration verification are invalid.

10.3.2.1 The analyst should carefully review all first-dimension chromatograms for the CCCs to ensure that the entire chromatographic peak elutes within the cut window. If this is not the case, the analyst should redetermine the cut window as per Section 10.2.2.

10.3.3 LABORATORY FORTIFIED SYNTHETIC SAMPLE MATRIX CCC STANDARD (LFSSM CCC) – As chromatographic columns age, column performance can deteriorate. This deterioration will typically result in a decreased retention time for bromate, which can affect the bromate retention time in high inorganic matrices. A LFSSM CCC must be analyzed daily in each Analysis Batch at a concentration equal to the high-level CCC to ensure that the first dimension cut window is functioning properly for high inorganic strength waters. The QC acceptance criteria for the LFSSM CCC is the same as for the high-level CCCs (within  $\pm 20\%$ ). If these conditions do not exist, then all data for the analyte must be considered invalid, and remedial action should be taken which may require the reestablishing the cut window (Sect. 10.2.2) and recalibration.

10.3.3.1 The analyst should carefully review all first-dimension chromatograms for the LFSSM CCC to ensure that the entire chromatographic peak elutes within the cut window. If this is not the case, the analyst should redetermine the cut window as per Section 10.2.2.

10.3.4 REMEDIAL ACTION – Failure to meet CCC or LFSSM CCC QC performance criteria requires remedial action. Maintenance such as confirming the integrity of the trapping efficiency of the concentrator column and matrix elimination step and/or regenerating or replacing the IC guard and analytical columns require returning to the initial calibration step (Sect. 10.2).

## 11. PROCEDURE

11.1 Important aspects of this analytical procedure include proper field sample collection, preservation and storage (Sect. 8), ensuring that the instrument is properly calibrated (Sect. 10.2) and that all required QC are met (Sect. 9) during each Analysis Batch. This section describes the procedures for field sample preparation and analysis. If alternative instrumentation and/or columns to those listed in this method are used, the procedure outlined in Sections 9.2 must be followed prior to analyzing field samples.

### 11.2 SAMPLE PREPARATION

11.2.1 Collect and store field samples as described in Section 8.

### 11.3 SAMPLE ANALYSIS

11.3.1 Establish the instrument operating conditions as described in Table 1 of Section 17. Confirm that the analyte retention times for the calibration standards are stable.

11.3.2 Establish a valid initial calibration following the procedures outlined in Section 10.2 or confirm that the calibration is still valid by running a low-level CCC as described in Section 10.3. If establishing an initial calibration for the first time, complete the IDC as described in Section 9.2.



- 11.3.3 Analyze field and QC samples at their required frequencies using the same conditions used to collect the initial calibration. Table 6 shows an acceptable analytical sequence that contains all method-required QC samples.
- 11.3.4 COMPOUND IDENTIFICATION – Establish an appropriate retention time window for bromate elution from the second dimension column in order to identify it in QC and field sample chromatograms.
- 11.3.4.1 Since the ionic strength of drinking water matrices may vary considerably, **the cut window (Sect. 10.2.2) for bromate in the first dimension must be set wide enough to account for the variability in the ionic strength of the drinking water matrices.** A window of approximately 2 minutes (using a 1.0 mL injection volume) was been found to be acceptable for the system used during method development. If the cut window is not set properly, analyte recoveries may be reduced without affecting the second-dimension retention times.
- 11.3.4.2 Retention times in the second dimension should be very stable as long as the first-dimension heart-cut window has been set properly (Sect. 10.2.2). This is because a majority of the common anions, which alter the ionic strength of field samples causing sample-to-sample variation in IC retention time, are eliminated during the heart-cut procedure. Retention times measured for bromate in RW and for the LFSSM were essentially identical during method development.
- 11.3.4.3 The QC requirements for each analysis batch include a first-dimension printout of the final CCC and the high level LFSSM CCC chromatograms to ensure the heart-cut window is functioning properly. The analyst should also review all first-dimension chromatograms to ensure acceptable chromatographic performance within the first-dimension cut window. For example, if a sample had a much higher conductivity (significantly above the LFSSM) caused by either very high levels of interfering anions or bromate, the first-dimension cut window would be overwhelmed. In such an instance, the sample should be diluted and reanalyzed.
- 11.3.4.4 High ionic strength matrices have the potential to cause an increase in background conductivity and severe tailing as the other anions elute from the first dimension column and cause the bromate retention time to decrease.
- 11.3.5 EXCEEDING CALIBRATION RANGE – The analyst must not extrapolate beyond the established calibration range. If an analyte result exceeds the range of the initial calibration curve, the field sample may be diluted with reagent water and the diluted field sample re-injected. Incorporate the dilution factor into final concentration calculations. The dilution will also affect the bromate MRL.

## **12. DATA ANALYSIS AND CALCULATIONS**

- 12.1 Identify the analyte present in the field and QC Samples as described in Section 11.3.4.
- 12.2 Calculate the bromate concentrations using the multi-point calibration established in Section 10.2. Quantify only those values that fall between the MRL and the highest calibration standard. Field samples with target analyte responses that exceed the highest calibration standard require dilution and reanalysis (Sect. 11.3.5).
  - 12.2.1 As noted in Section 9.3.5.2.1, it may be necessary to extrapolate below the MRL to estimate contaminants in LRBs and to correct for native levels of bromate below the MRL when field samples are fortified at or near the MRL. These are the only permitted use of analyte results below the MRL.
- 12.3 Calculations must utilize all available digits of precision, but final reported concentrations should be rounded to an appropriate number of significant figures (one digit of uncertainty), typically two, and not more than three significant figures.
- 12.4 Prior to reporting data, the laboratory is responsible for assuring that QC requirements have been met or that any appropriate qualifier is documented.

## **13. METHOD PERFORMANCE**

- 13.1 PRECISION, ACCURACY AND DETECTION LIMITS – Tables for these data are presented in Section 17. The LCMRL for bromate is presented in Table 2 and was calculated using a procedure described elsewhere.<sup>1</sup> The DL data is also reported in Table 2. Single laboratory precision and accuracy data are presented in Table 3.
- 13.2 Figure 3 is a representation of both the first and second dimension chromatograms for a 15 µg/L bromate fortification in the LSSM and Figure 4 shows similar chromatograms for a 0.50 µg/L bromate fortification to a municipal ground water, disinfected with chlorine.

## **14. POLLUTION PREVENTION**

- 14.1 For information about pollution prevention that may be applicable to laboratory operations, consult “Less is Better: Laboratory Chemical Management for Waste Reduction” available from the American Chemical Society’s Department of Government Relations and Science Policy, 1155 16th Street N.W., Washington, D.C., 20036, or on-line at:  
[http://www.ups.edu/community/storeroom/Chemical\\_Wastes/wastearicles.htm](http://www.ups.edu/community/storeroom/Chemical_Wastes/wastearicles.htm).

## **15. WASTE MANAGEMENT**

- 15.1 The analytical procedures described in this method generate relatively small amounts of waste since only small amounts of reagents are used. The matrices of concern are finished drinking water or source water. However, the Agency requires that laboratory waste management practices be conducted consistent with all applicable rules and regulations, and that laboratories protect the air, water, and land by minimizing and controlling all releases from

fume hoods and bench operations. Also, compliance is required with any sewage discharge permits and regulations, particularly the hazardous waste identification rules and land disposal restrictions. For further information on waste management, see the publications of the American Chemical Society's Laboratory Environment, Health & Safety Task Force on the Internet at <http://membership.acs.org/c/ccs/publications.htm>. Or see "Laboratory Waste Minimization and Pollution Prevention," Copyright © 1996 Battelle Seattle Research Center, which can be found at <http://www.p2pays.org/ref/01/text/00779/index2.htm>.

## 16. REFERENCES

1. Winslow, S. D.; Pepich, B. V.; Martin, J. J.; Hallberg, G. R.; Munch, D. J.; Frebis, C. P.; Hedrick, E. J.; Krop, R. A. Statistical Procedures for Determination and Verification of Minimum Reporting Levels for Drinking Water Methods. *Environ. Sci. & Technol.* **2006**, 40, 281-288.
2. Glaser, J.A.; Foerst, D.L.; McKee, G. D.; Quave, S. A.; Budde, W. L. Trace Analyses for Wastewaters, *Environ. Sci. & Technol.* **1981**, 15, 1426-1435.
3. *Safety in Academic Chemistry Laboratories*; American Chemical Society Publication, Committee on Chemical Safety, 7<sup>th</sup> Edition: Washington, D.C., 2003.
4. *Occupational Exposures to Hazardous Chemical in Laboratories*; 29 CFR 1910.1450, Occupational Safety and Health Administration, 1990.
5. "Guidelines, Recommendations, and Regulations for Handling Antineoplastic Agents", Center for Disease Control, National Institute for Occupational Safety and Health, <http://www.cdc.gov/niosh/topics/antineoplastic/pubs.html#b>
6. *Standard Practice for Sampling Water from Closed Conduits*; ASTM Annual Book of Standards, Section 11, Volume 11.01, D3370-82, American Society for Testing and Materials: Philadelphia, PA, 2008.

## **17.0 TABLES, DIAGRAMS, FLOWCHARTS, AND VALIDATION DATA**

**TABLE 1. INSTRUMENTAL CONDITIONS USED DURING METHOD DEVELOPMENT**

### **Standard Conditions and Equipment for First Dimension Analyses<sup>a,b</sup>:**

Ion Chromatograph:	Dionex ICS-3000 Dual System
Sample loop:	1.0 mL
Load Volume:	1000 µL
Eluent Generator:	Dionex ICS-3000 EG Eluent Generator Module (P/N 061714), with dual channel EluGen Cartridges (P/N 058900), isocratic 10 mM potassium hydroxide step changed or ramped to 65 mM potassium hydroxide following the elution of bromate (when injection valve #2 is switched to the inject position)
Eluent Flow:	1.0 mL/min
Autosampler:	AS Autosampler Module (P/N 063105) Sample Prep options and a large volume (8.2 mL) sample needle assembly (P/N 061267)
Columns :	Dionex IonPac AG 19 Guard 4 x 50 mm (P/N 062887) Dionex IonPac AS 19 Analytical 4 x 250 mm (P/N 062885)
Typical System Back-pressure:	~2300 psi
Conductivity Suppressor:	Dionex ASRS Ultra II, 4-mm (P/N 061561) with 4-mm Carbonate Removal Device (CRD, P/N 062983)
Chromatography Module	DC-Module (P/N 061793) maintained @ 30° C
Detector:	Conductivity Detector with integrated cell (P/N 061716) held @ 35° C
Total analysis time:	35 min

### **Standard Conditions and Equipment for Second Dimension Analyses<sup>a,b</sup>:**

Ion Chromatograph:	Dionex ICS-3000 Dual System
Sample loop:	Dionex UTAC-ULP1, 5 x 23-mm, concentrator column (P/N 063475)
Load Volume:	Cut-window time set per procedures in Section 10.2.2 (approximately 2.0 mL)
Eluent Generator:	Dionex ICS-3000 EG Eluent Generator Module (P/N 061714), with dual channel EluGen Cartridges (P/N 058900), isocratic 10 mM potassium hydroxide step changed or ramped to 65 mM potassium hydroxide following the elution of bromate for approximately 10 minutes and re-equilibrate at 10 mM hydroxide prior to injection
Eluent Flow:	0.25 mL/min
Columns :	Dionex IonPac AG 24 Guard 2 x 50 mm (P/N 064151) Dionex IonPac AS 24 Analytical 2 x 250 mm (P/N 064153)
Typical System Back-pressure:	~2300 psi
Conductivity Suppressor:	Dionex ASRS Ultra II, 2-mm (P/N 061562) with 2-mm Carbonate Removal Device (CRD, P/N 062986)
Chromatography Module	DC-Module (P/N 061793) maintained @ 30° C
Detector:	Conductivity Detector with integrated cell (P/N 061716) held @ 35° C
Total analysis time:	35 min

- (a) Mention of trade names or commercial products does not constitute endorsement or recommendation for use. (b) It is the responsibility of the analyst to assure that the instruments, supplies, and conditions used are capable of meeting all method QC requirements.

**TABLE 2. LOWEST CONCENTRATION MRL AND DL FOR BROMATE WITH 2-D IC**

<b>Injection Volume</b>	<b>Analyte</b>	<b>LCMRL<sup>a</sup> (µg/L)</b>	<b>*DL (µg/L)</b>
1.0 mL	BrO <sub>3</sub> <sup>-</sup>	0.18	0.12 <sup>b</sup>

<sup>a</sup>LCMRL was calculated according to the procedure in reference 1.

\*The DL was calculated from data acquired on a single day.

<sup>b</sup>Replicate fortifications at 0.20 µg/L.

**TABLE 3. IC PRECISION AND RECOVERY DATA FOR BROMATE IN VARIOUS MATRICES WITH 2-D IC (n=7) USING A 1.0-mL INJECTION VOLUME**

<b>Matrix</b>	<b>Spiked Conc. (µg/L)</b>	<b>Unspiked Conc. (µg/L)</b>	<b>Mean % Rec.</b>	<b>% RSD</b>
Reagent Water	0.50	<0.18	101	1.1
	5.0	<0.18	99.1	1.2
*LFSSM	0.50	<0.18	104	2.6
	5.0	<0.18	96.2	1.0
Ground water	0.50	0.63	96.1	1.7
	5.0	0.63	100	0.94
Surface water 1	0.50	0.46	89.8	0.84
	5.0	0.46	103	1.2

\*Described in Section 3.11 and 7.2.2

**TABLE 4. INITIAL DEMONSTRATION OF CAPABILITY QUALITY CONTROL REQUIREMENTS**

<b>Method Reference</b>	<b>Requirement</b>	<b>Specification and Frequency</b>	<b>Acceptance Criteria</b>
Section 9.2.1	Demonstration of Low System Background	Analyze a LRB prior to any other IDC steps.	Demonstrate that bromate is below 1/3 of the MRL (Section 9.3.1) and that possible interferences from sampling protocols do not prevent the identification and quantification of bromate.
Section 9.2.2	Demonstration of Precision	Analyze 7 replicate LFBs and LFSSMs fortified near the mid-point of the calibration curve	%RSD must be $\leq 20\%$ .
Section 9.2.3	Demonstration of Accuracy	Calculate average recovery for replicates used in Section 9.2.2.	Mean recovery within $\pm 20\%$ of true value.
Section 9.2.5	Quality Control Sample	During IDC, each time a new analyte PDS is made, every time the instrument is calibrated and at least quarterly.	The result for bromate must be within 80-120% of the true value.

**TABLE 5. ONGOING QUALITY CONTROL REQUIREMENTS (SUMMARY)**

<b>Method Reference</b>	<b>Requirement</b>	<b>Specification and Frequency</b>	<b>Acceptance Criteria</b>
Section 8.3	Sample Holding Time	28 days when collected and stored according to sections 8.1 and 8.2 with appropriate storage.	Sample results are valid only if samples are analyzed within sample hold time.
Section 9.3.1	Laboratory Reagent Blank (LRB)	Analyze a LRB as part of the IDC (Section 9.2), as part of each calibration, and with each Analysis Batch	Demonstrate that bromate is below 1/3 of the MRL and that possible interferences from sampling protocols do not prevent the identification and quantification of bromate.
Section 9.3.2 And 10.3	Continuing Calibration Check (CCC) Standards	Verify initial calibration by analyzing a low-level CCC at the beginning of each Analysis Batch. Subsequent CCCs are required after every 10 field samples, and after the last field sample in a batch. Low CCC – at or below the MRL concentration Mid CCC – near midpoint in calibration curve High CCC – near the highest calibration standard.	For each CCC the result must be: For CCCs ≤ MRL: % Rec within ± 50% of the true value  For CCCs > MRL: %Rec within ± 20% of the true value  Recalibration is recommended if these criteria are not met.
Section 9.3.3	Laboratory Fortified Synthetic Sample Matrix CCCs (LFSSM CCC)	In order monitor the cut window during an Analysis Batch, a high-level CCC standard, prepared in the LFSSM (Sect. 9.3.3) is also required near the beginning of each Analysis Batch.	For the LFSSM CCC the result must be within ± 20% of the true value
Section 9.3.4	Laboratory Fortified Blank (LFB)	Analyze a LFB with each analysis batch, rotating between low, medium and high concentration from batch to batch.  Low LFB – at or below the MRL concentration Mid LFB – near midpoint in calibration curve High LFB – near the highest calibration standard.	For each LFB the result must be: For LFBs ≤ MRL: % Rec within ± 50% of the true value  For LFBs > MRL: %Rec within ± 20% of the true value  Recalibration is recommended if these criteria are not met.

**TABLE 5. ONGOING QUALITY CONTROL REQUIREMENTS (Continued)**

Method Reference	Requirement	Specification and Frequency	Acceptance Criteria
Section 9.3.5	Laboratory Fortified Sample Matrix (LFSM)	Analyze one LFSM per Analysis Batch (20 field samples or less). Fortify the LFSM with bromate at a concentration close to but greater than the native concentration (if known). Calculate LFSM recoveries.	Recoveries for the LFSM must be calculated (Sect. 9.3.5.2). The result must be:  For LFSMs ≤ MRL: % Rec within ± 50% of the true value  For LFSMs > MRL: %Rec within ± 20% of the true value
Section 9.3.6	Laboratory Duplicate (LD) or Laboratory Fortified Sample Matrix Duplicate (LFSMD)	Analyze at least one LD or LFSMD daily, or with each Analysis Batch (20 samples or less), whichever is more frequent.	RPD must be calculated (Sect. 9.3.6.1 for LD and Sect. 9.3.6.3 for LFSMD). The result must be:  For LFSMDs ≤ MRL: % Rec within ± 50% of the true value  For LFSMDs > MRL: %Rec within ± 20% of the true value
Section 9.3.7	Quality Control Sample (QCS)	During IDC, each time a new analyte PDS is made, every time the instrument is calibrated and at least quarterly.	Results must be within ± 20% of the expected value.
Section 10.2	Initial Calibration	Use external standard calibration technique to generate a first or second order calibration curve. Use at least 5 standard concentrations. Check the calibration curve as described in Section 10.2.  Analyze a QCS near the mid-point of the calibration curve.	When each calibration standard is calculated as an unknown using the calibration curve, the result should be: For CALs ≤ MRL: % Rec within ± 50% of the true value  For CALs > MRL: %Rec within ± 20% of the true value  Recalibration is recommended if these criteria are not met.



**TABLE 6. SAMPLE ANALYSIS BATCH WITH QC REQUIREMENTS**

<b>Injection #</b>	<b>Sample Description</b>	<b>Acceptance Criteria</b>
1	Laboratory Reagent Blank (LRB)	$\leq 1/3$ MRL
2	CCC at the MRL	Recovery of 50 - 150%
3	LFSSM CCC at high level	Recovery of 80 – 120%
4	LFB	$\leq$ MRL 50-150% of value $>$ MRL 80-120% of value
5	Sample 1	normal analysis
6	Sample 2	normal analysis
7	Sample 2 - Laboratory Fortified Sample Matrix (LFSM)	Recovery of 80 - 120%
8	Sample 2 - Laboratory Fortified Sample Matrix Duplicate (LFSMD)	%RPD = $\pm 20\%$
9	Sample 3	normal analysis
10	Sample 4	normal analysis
11	Sample 5	normal analysis
12	Sample 6	normal analysis
13	Sample 7	normal analysis
14	Sample 8	normal analysis
15	Sample 9	normal analysis
16	Sample 10	normal analysis
17	CCC at mid level	Recovery of 80 - 120%
18	Sample 11	normal analysis
19	Sample 12	normal analysis
20	Sample 13	normal analysis

**CONTINUED on NEXT PAGE**

**TABLE 6. (Continued)**

<b>Injection #</b>	<b>Sample Description</b>	<b>Acceptance Criteria</b>
21	Sample 14	normal analysis
22	Sample 15	normal analysis
23	Sample 16	normal analysis
24	Sample 17	normal analysis
25	Sample 18	normal analysis
26	Sample 19	normal analysis
27	Sample 20	normal analysis
28	CCC at high level*	Recovery of 80 - 120%

\* also requires first dimension chromatogram printout

Figure 1. EPA Method 302.0 System Schematic

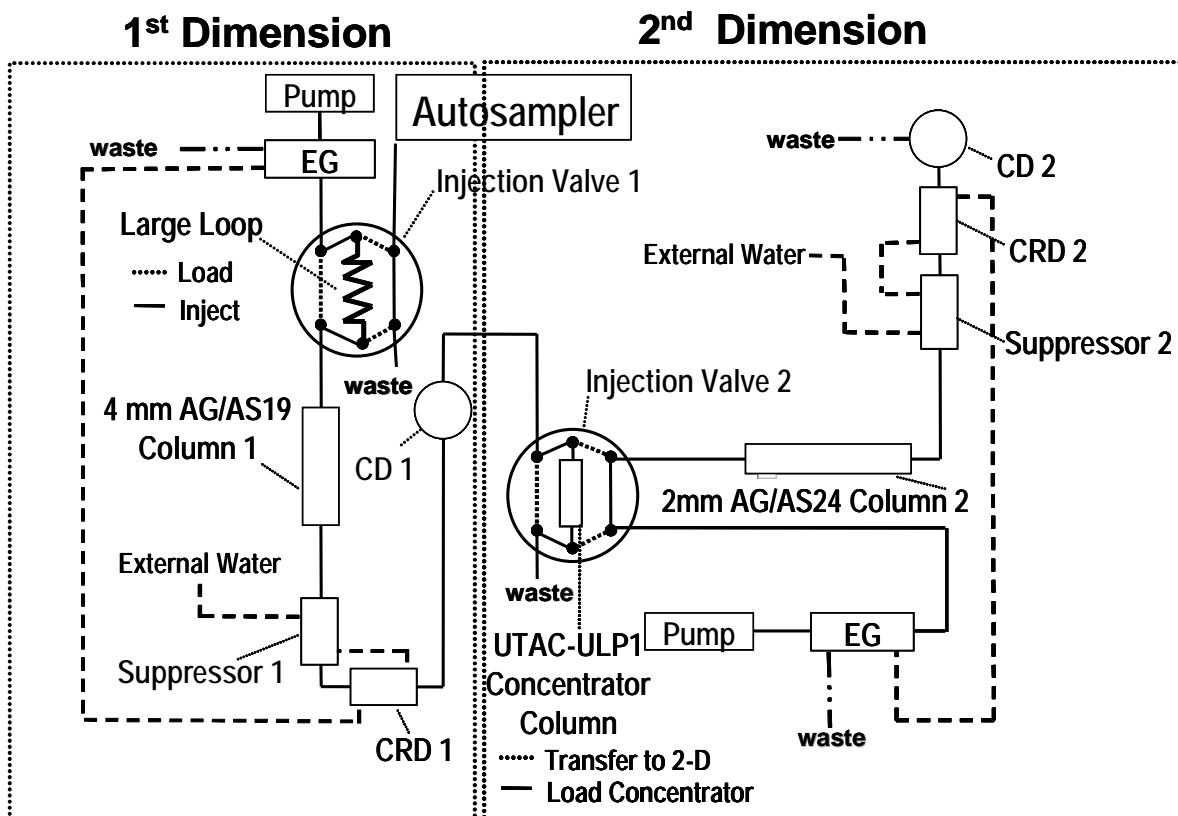

**Figure 2. Setting the start and stop time for the cut window in the first dimension using a 1.0-mL injection volume of a 15  $\mu\text{g/L}$   $\text{BrO}_3^-$  fortification in the LSSM and RW.**

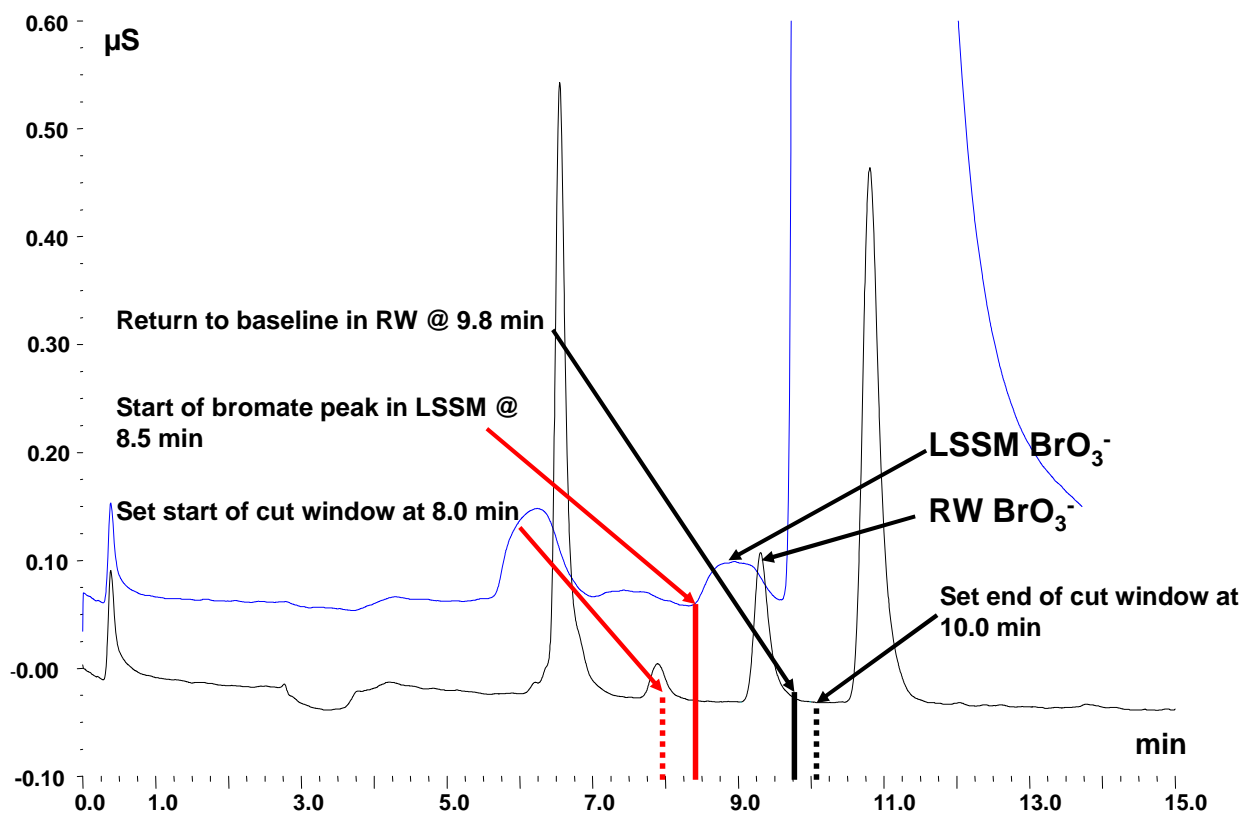

Figure 3. First and Second Dimension Chromatogram of 15.0  $\mu\text{g/L}$  bromate fortification in the LSSM.

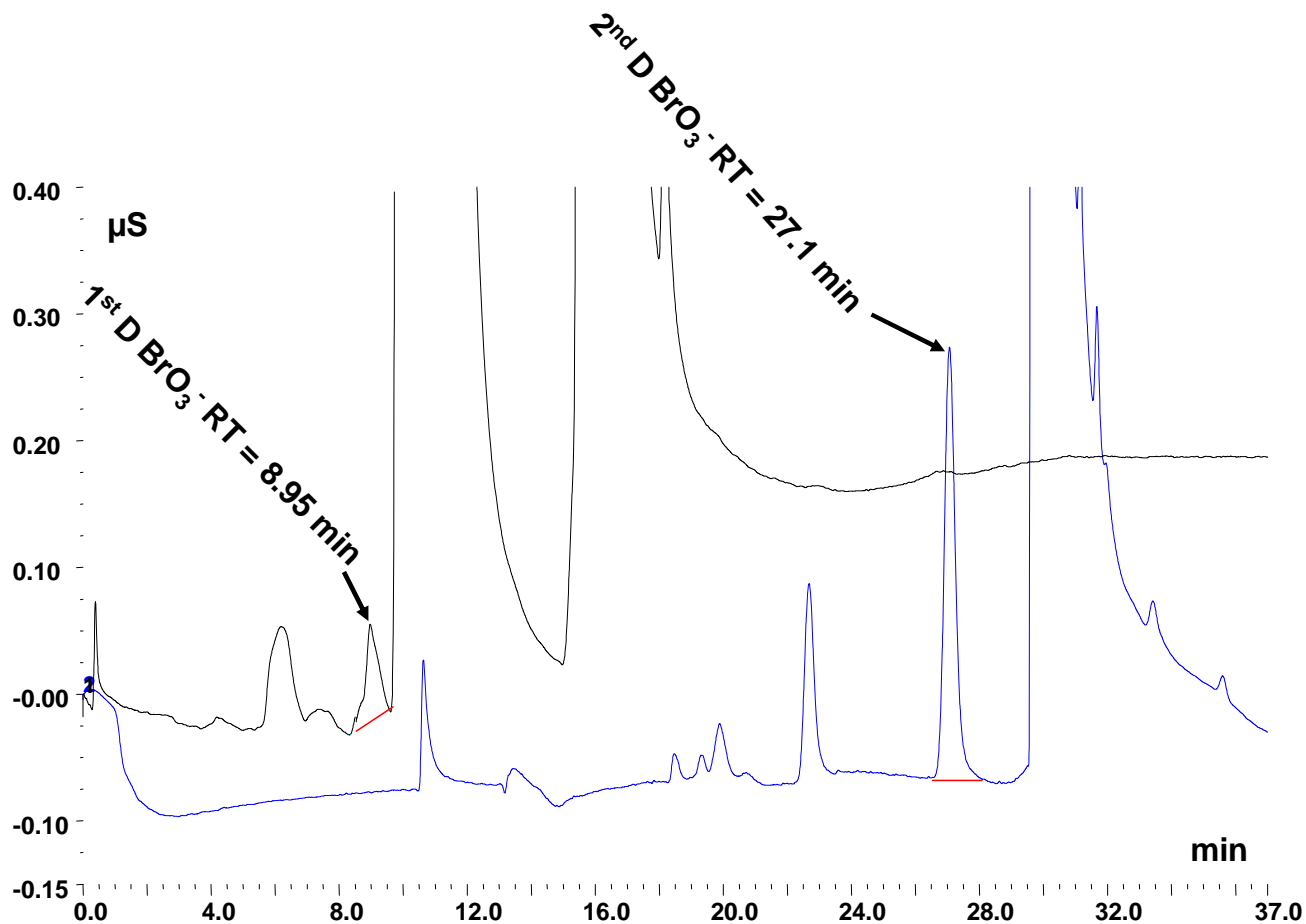

Figure 4. Typical 1<sup>st</sup> and 2<sup>nd</sup> Dimension Chromatogram of a municipal groundwater disinfected with chlorine and fortified with 0.50  $\mu\text{g/L}$  bromate. The native level of bromate was 0.41  $\mu\text{g/L}$  and recovery was 104 percent.

